

## Agilext FD50 - Corded

Agilext FD50 is a nominal two inch pitch, full drive bar, positive drive food conveyor belt that reduces the risk of microbiological propagation as well as foreign matter contamination from belt breakage. The belt is Clean-In-Place (CIP) appropriate and will reduce water usage and waste water disposal costs when compared to other belt types.

### Product Specifications

Belt Type	Full Drive Bar	
Designator	<b>FD50</b>	
Color	Light Blue, Dark Blue, White	
Hardness, Shore D	55	
Pitch (mm)	50	
Thickness (mm)	3	
Roll Stock Width (mm)	450 to 1,500	
Roll Stock Length (meters)	60	
Belt Weight (Kg/m <sup>2</sup> )	4.2	
Min. Pulley Dia. (mm)		
> -4° C +	100	
< -4° C	150	
Min Backbend Dia. (mm)		
> -4° C +	150	
< -4° C	250	
Service Temperature Range C°	-10 to 70	
C of Friction (dynamic/static)		
vs. UHMW	Wet	.35/.58
	Dry	.20/.30
vs. Stainless Steel	Wet	.40/.57
	Dry	.38/.41
Tensile Force for 2% Elongation (N/mm)	11.4	

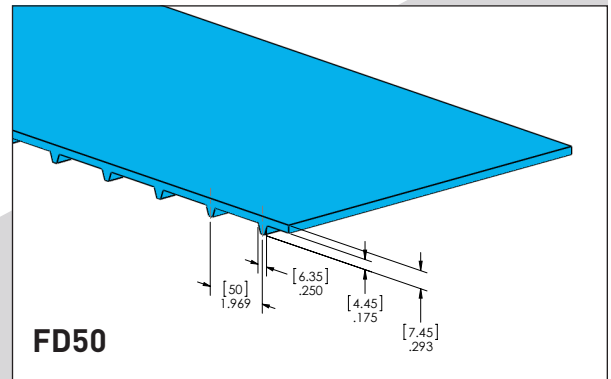

### Product Construction

Resin	Ether Grade Polyurethane
Surface Finishes	Matte (Standard)
	Gloss
	Inverted Pyramid
	Diamond Pattern with Oval Bottom (High Release Properties)
	Crescent
	Sawtooth
Regulatory	Conforms to EU No. 10/2011
	USDA Certified for Compliance with USDA Dairy Equipment Guidelines

# Agilext FD50 - Corded

## Sprocket Guidelines

Belt Width	150 mm	225 mm	300 mm	375 mm	450 mm	525 mm	600 mm	700 mm	750 mm	900 mm	1000 mm	1150 mm	1200 mm
	6"	9"	12"	15"	18"	21"	24"	27"	30"	36"	40"	45"	48"
<b>Min. No. Sprockets</b> <small>Max. 5" (127 mm) spacing center - center</small>	3	3	4	4	5	6	6	7	7	8	9	10	11
<b>No. Sprockets for Max. Allow. Tension</b> <small>Max. 3" (76 mm) spacing center to center</small>	3	4	5	6	7	8	9	10	11	13	15	16	17
<b>Min. No. Carryway Supports</b> <small>6" (152 mm) spacing center to center</small>	2	3	3	4	4	5	5	6	6	7	8	9	9

### Disclaimer

All information as to the application, use and performance of the products are recommendations but no representations or warranties of any kind are made as to their completeness, accuracy or suitability for a particular purpose. These products are provided "as is". Agilext disclaims all other warranties, either express or implied, including, but not limited to, implied warranties of merchantability, fitness for a particular purpose, non-infringement, or arising from a course of dealing, usage or trade practice, all of which are hereby excluded to the extent allowed by applicable law. Agilext does not assume any liability concerning the suitability and processability of the products, including indications on process results and output.



**Agilext**

75 Walch Drive  
Portland, ME 04103

sales@agilext.com

+1 207 878-4400

agilext.com